

CityLink helps the Bible Society to see the “light!”

When the product you work with is 2,000 years old, it can be hard to see the value of new solutions. Thankfully that isn't the case with the Bible Society in New Zealand, their mission since 1846 has been to get Bibles into hands and hearts everywhere. As well as being a major distributor of Bibles within New Zealand, working closely with churches, the general book trade and specialist Christian bookshops and training organisations, the Bible Society also takes in funds to support the translation, publication and distribution of Bibles internationally.

Based in Wellington the Bible Society employs 35 people, including 10 who are on the road most of the time. Staying in touch with customers all over the country and supporting a mobile workforce created a challenge that has now been successfully met by CityLink and ORCON, the Bible Society's ISP.

The Bible Society's challenge

The Bible Society needs robust telecommunications to operate everything from the needs of the head office team in Wellington for reliable voice communications and internet access and the need for remote VPN access for the “Road Warriors”.

Like many small and medium sized New Zealand organisations the Bible Society bought its voice and internet services from a major telco, but they were increasingly frustrated by unreliable connections.

“The old connection was incredibly frustrating, it kept crashing all the time and had a really negative impact on our work” explains Jo Leiper a Project Officer with the Bible Society.

BIBLE SOCIETY: PREVIOUS “COPPER” BASED SERVICES

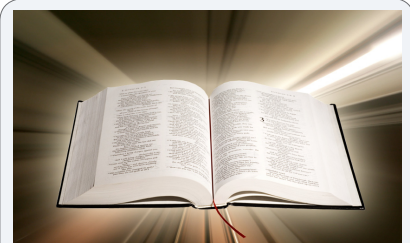
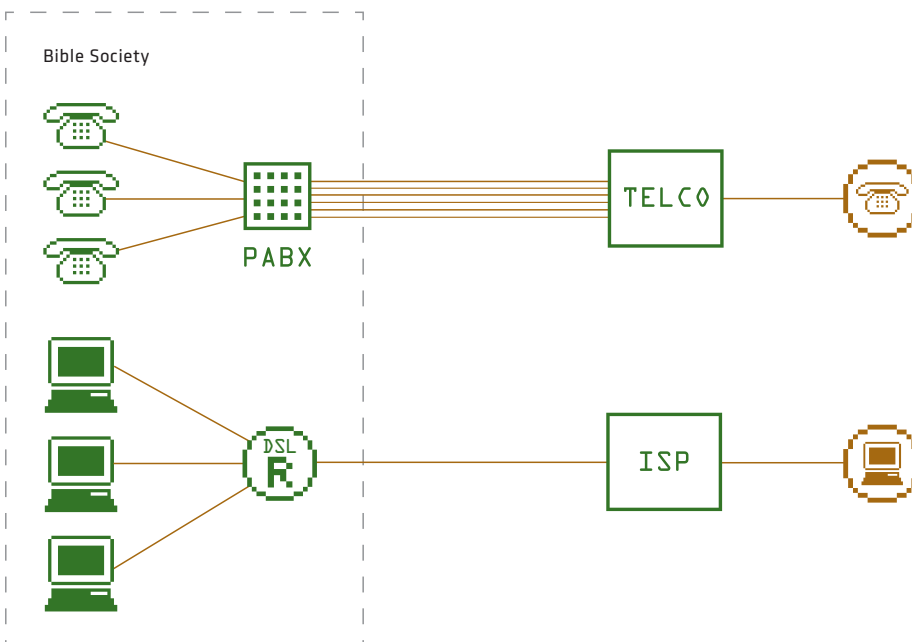

In This Article

» By taking advantage of easy access to the CityLink fibre optic network, the Bible Society has been able to enjoy the benefits of the latest advanced business communication tools and technologies.

Products featured in this article:

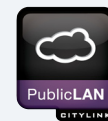

“CityLink is fundamental to the functioning of the business now. We couldn't live without it.”

Jo Leiper, Project Officer, Bible Society

Jo had worked with CityLink at her previous job and when she came on board in April 2008 she was delighted to discover that CityLink was already in the building and by September the Bible Society switched over and everything changed.

CityLink's solution - "Let there be light!"

By taking advantage of CityLink already being in the building the Bible Society is able to access the Internet at 25Mb/s over a PublicLAN connection to CityLink's Wellington fibre optic broadband Metropolitan Area Network.

This didn't just improve the Bible Society's Internet connection, it also enabled Orcon (the Bible Society's ISP) to replace the Bible Society's existing copper based telephone services with a 'SIP Trunk'. That allows Orcon to deliver telephone services directly over the CityLink network, sharing the connection with the Internet and VPN. As a single physical network is used, costs are reduced without affecting reliability or quality. And Orcon offers significantly reduced calling rates and free local calling.

Is CityLink in your building?

» CityLink currently connects over 450 buildings in central Wellington and 50 major buildings in downtown Auckland, give us a call to see if your location is currently connected or how close we are. You can call us on 0800 4 CITYLINK (0800 424 895) or email sales@citylink.co.nz

BIBLE SOCIETY: CITYLINK PUBLICLAN BASED SOLUTION

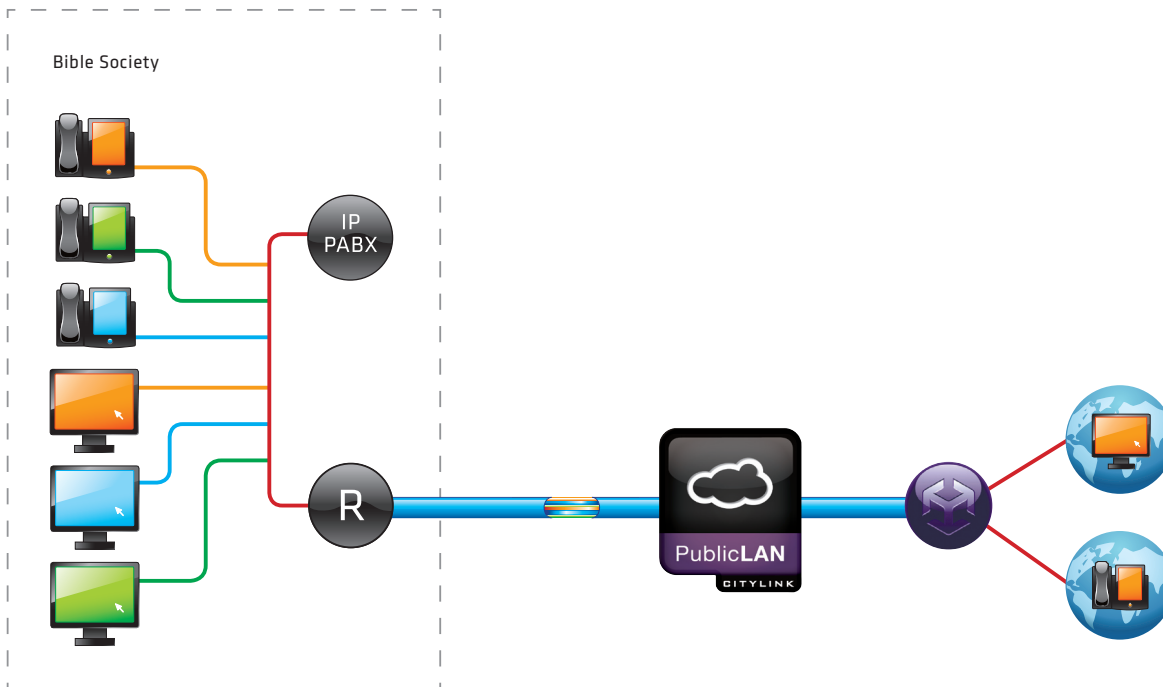

KEY:

- 

Internet Protocol Private Automatic Branch Exchange
- 

Router
- 

CityLink Fibre Optics
- 

Orcon (Internet Service Provider)
- 

Global Telephone Network
- 

Global Internet

Benefits of "Biblical" proportions

Thanks to its new fibre connection the Bible Society now has far greater control over its communications and has reduced its costs on both hardware and calls, remote workers can easily be part of the office voice network with remote telephone extensions and future upgrades are now both simpler and cheaper.

While Jo Leiper has already seen dramatic "overnight" improvements just from the speed and reliability of the Bible Society's connection to CityLink's PublicLAN network that have already streamlined their communications, but it doesn't stop there "We've got some big changes coming throughout the next year or two – including a new financial system, which our reps can access remotely, and we're also working toward an online donation system," she says. "We believe the infrastructure we have in place now will help carry us through all these changes easily and reliably. CityLink is fundamental to the functioning of the business now. We couldn't live without it."